

**OPERATION & SERVICE MANUAL**  
**MANUAL HAND PUMP STACKER**  
**MODEL: VHPS-2000-AA & VHPS-2000-FF**





**SPECIFICATION**

| Model Number            |          | VHPS-2000-AA                           | VHPS-2000-FF                           |
|-------------------------|----------|----------------------------------------|----------------------------------------|
| Capacity                |          | 2,000 lbs                              | 2,000 lbs                              |
| Raised Height           |          | 62"                                    | 62"                                    |
| Lowered Height          |          | 1 <sup>3</sup> / <sub>8</sub> "        | 3 <sup>3</sup> / <sub>4</sub> "        |
| Fork Dimensions (LxWxH) |          | 42x5.9x2 <sup>3</sup> / <sub>8</sub> " | 42x5.9x2 <sup>3</sup> / <sub>8</sub> " |
| Overall Fork Width      |          | 27"                                    | 27"                                    |
| Ground Clearance        |          | 1"                                     | 1"                                     |
| Overall Mast Height     |          | 78"                                    | 78"                                    |
| Loading Center          |          | 21"                                    | 21"                                    |
| Wheel Base              |          | 41-5/16"                               | 41-5/16"                               |
| Turning Radius          |          | 45-11/16"                              | 45-11/16"                              |
| Steering Wheel          |          | Ø7x2"                                  | Ø7x2"                                  |
| Front Load Roller       |          | Ø4x2.91"                               | Ø4x2.91"                               |
| Overall Size (LxWxH)    |          | 61 <sup>1</sup> / <sub>4</sub> x46x78" | 61 <sup>1</sup> / <sub>4</sub> x27x78" |
| Lift Speed (# of pumps) | Loaded   | 87                                     | 87                                     |
|                         | Unloaded | 85                                     | 85                                     |
| Down Speed              | Loaded   | 15 secs                                | 15 secs                                |
|                         | Unloaded | 11 secs                                | 11 secs                                |
| Aisle Width             |          | 32"                                    | 32"                                    |
| Net Weight              |          | 818                                    | 748                                    |

# CONTENTS

|                                                      |    |
|------------------------------------------------------|----|
| <b>General</b> .....                                 | 2  |
| <b>EC Declaration of Conformity</b> .....            | 3  |
| <b>Specification</b> .....                           | 4  |
| <b>Contents</b> .....                                | 5  |
| <b>Safety Notes</b> .....                            | 6  |
| Safety instructions .....                            | 6  |
| Symbols and pictograms used .....                    | 7  |
| Routines, personnel, skills .....                    | 8  |
| General principles .....                             | 9  |
| <b>Product description</b> .....                     | 10 |
| Designated use .....                                 | 10 |
| Signs on the truck .....                             | 11 |
| <br>                                                 |    |
| <b>Taking into operation/ Trouble shooting</b> ..... | 13 |
| <br>                                                 |    |
| <b>Operating</b> .....                               | 14 |
| Raising the load .....                               | 14 |
| Driving on sloping surfaces.....                     | 15 |
| Parking brake .....                                  | 16 |
| <br>                                                 |    |
| <b>Maintenance and repair</b> .....                  | 17 |
| Maintenance—daily/monthly/ 6 monthly.....            | 17 |
| Maintenance and care of the load chains .....        | 18 |
| Chain inspections .....                              | 19 |
| Temporary lay-up .....                               | 20 |

## **Safety notes**

---

### **Safety instructions**

This chapter informs the user about residual dangers relating to the correct use of the products. It contains generally valid safety instructions which must be observed.

Safety instructions relating to specific actions or situations are listed prior to the respective action and/or description of the situation in the chapter.

### **Principles**

This product complies with state-of-the-art technical standards and recognized safety regulations, but there are still dangers which may occur which must be considered.

Only operate the product in a perfect condition and observing the information contained in the operating manual.

The operator is responsible for integrating the product with as little risk as possible into his working environment. This obligation continues through every phase of the products lifespan, beginning at the planning stage. Residual dangers are to be minimized.

Only trained, competent personnel who have been instructed using the operating manual and the product are permitted to work with the truck.

The operating manual must be understood (responsibility, checking)

### **Liability or guarantee is waived if:**

- The instructions in this operating manual are not observed.
- The high-lift stacking truck is operated, cleaned or maintained incorrectly.
- Alterations to the functions are carried out without the consent of manufacturer.
- Original spare parts are not used.

The operating manual should be supplemented with instructions derived from valid national regulations governing accident prevention and the protection of the environment.

---

---

---

---

---

---

---

---

## Safety notes

### Symbols and pictograms used

In addition to the text and illustrations, this operating manual contains various symbols which should draw attention to the safety requirements.









They generally have the following appearance:

| Signal wording | Explanation                                                                                                       |
|----------------|-------------------------------------------------------------------------------------------------------------------|
| <b>DANGER</b>  | Warning of an imminent danger!<br>Non-observance cause death or serious injury                                    |
| <b>WARNING</b> | Warning of a possibly incoming dangerous situation.<br>Non-observance may cause death or serious injury.          |
| <b>CAUTION</b> | Warning of a possibly incoming dangerous situation.<br>May also be used for warnings of major damage to property. |

Other definitions:

|                  |                                                                                                       |
|------------------|-------------------------------------------------------------------------------------------------------|
| <b>DIRECTION</b> | Marks recommendations for use and other useful information.<br>Does not warn of dangerous situations. |
| <b>IMPORTANT</b> | Warns of a harmful situation.<br>Non-observance may cause damage to material.                         |

### Used symbols and pictograms

|                                                                                     |                                                    |                                                                                      |                                              |
|-------------------------------------------------------------------------------------|----------------------------------------------------|--------------------------------------------------------------------------------------|----------------------------------------------|
|  | Possible danger to<br>file and limb or<br>machine! |  | Do not step onto when<br>load is raised!     |
|  | Danger of crushing!                                |  | It is forbidden to ride<br>on the truck!     |
|  | Do not reach into<br>running motor!                |  | Suspension points for<br>transport of truck! |
|  | Wear safety shoes                                  |   | Important                                    |
|  | Wear helmet                                        |  | Suspended load<br>warning!                   |

## Safety notes

---

### Routines, personnel, skills

| What must be done?                                                                                                                                                                                                                                                                                                                                                                                                                                                                                                                                                                                                                                                                                                                                             | Who is responsible?                                                                         |
|----------------------------------------------------------------------------------------------------------------------------------------------------------------------------------------------------------------------------------------------------------------------------------------------------------------------------------------------------------------------------------------------------------------------------------------------------------------------------------------------------------------------------------------------------------------------------------------------------------------------------------------------------------------------------------------------------------------------------------------------------------------|---------------------------------------------------------------------------------------------|
| <ul style="list-style-type: none"> <li>- Initial operation</li> <li>- Selection and instruction of personnel</li> <li>- Allocation of authorizations</li> <li>- Instructing and controlling</li> <li>- Analysis of dangers when in operation</li> <li>- Appointing of working areas</li> <li>- Appointment and release of driving areas</li> <li>- Sign-posting dangerous points on driving area with the typical road signs and any additional signs if necessary</li> <li>- Evaluation of erroneous actions</li> <li>- Evaluation of arising faults</li> <li>- Reporting faults which have arisen</li> <li>- Reporting faults and defects of product and/or the instruction manual to the manufacturer</li> <li>- Enforcement of the availability</li> </ul> | <ul style="list-style-type: none"> <li>- Head of this responsibility area</li> </ul>        |
| <ul style="list-style-type: none"> <li>- Operating and installation of the lifting trucks</li> <li>- Registering and reporting faults</li> <li>- Initiating maintenance and repair</li> <li>- Cleaning and care</li> <li>- Securing the machine against unauthorized use(remove the key)</li> </ul>                                                                                                                                                                                                                                                                                                                                                                                                                                                            | <ul style="list-style-type: none"> <li>- Operator (skilled employee)</li> </ul>             |
| <ul style="list-style-type: none"> <li>- Operating the lift trucks</li> <li>- Reporting faults</li> <li>- Initiating maintenance and repairs</li> <li>- Cleaning and care</li> <li>- Securing the machine against unauthorized use(remove the key)</li> </ul>                                                                                                                                                                                                                                                                                                                                                                                                                                                                                                  | <ul style="list-style-type: none"> <li>- Operator (trained employee)</li> </ul>             |
| <ul style="list-style-type: none"> <li>- Mechanical work</li> </ul>                                                                                                                                                                                                                                                                                                                                                                                                                                                                                                                                                                                                                                                                                            | <ul style="list-style-type: none"> <li>- Mechanic (skilled employee)</li> </ul>             |
| <ul style="list-style-type: none"> <li>- Electrical work</li> </ul>                                                                                                                                                                                                                                                                                                                                                                                                                                                                                                                                                                                                                                                                                            | <ul style="list-style-type: none"> <li>- Electrician (skilled employee)</li> </ul>          |
| <ul style="list-style-type: none"> <li>- Battery maintenance</li> </ul>                                                                                                                                                                                                                                                                                                                                                                                                                                                                                                                                                                                                                                                                                        | <ul style="list-style-type: none"> <li>- Skilled employee</li> </ul>                        |
| <ul style="list-style-type: none"> <li>- Annual inspection of the lifting truck</li> </ul>                                                                                                                                                                                                                                                                                                                                                                                                                                                                                                                                                                                                                                                                     | <ul style="list-style-type: none"> <li>- Service staff (expert)</li> </ul>                  |
| <ul style="list-style-type: none"> <li>- Transport</li> </ul>                                                                                                                                                                                                                                                                                                                                                                                                                                                                                                                                                                                                                                                                                                  | <ul style="list-style-type: none"> <li>- Appropriate expert</li> </ul>                      |
| <ul style="list-style-type: none"> <li>- Maintenance</li> <li>- Repairs</li> </ul>                                                                                                                                                                                                                                                                                                                                                                                                                                                                                                                                                                                                                                                                             | <ul style="list-style-type: none"> <li>- Qualified, trained specialist personnel</li> </ul> |





## Product description

---

### Designated use

- ❖ The stacker is designated for the lifting, lowering and transportation of loads according to the specifications of the identification plate.
- ❖ The stacker is to be used on level surfaces.
  - To move the stacker between buildings, warehouses etc
    - The gradient of the slope must not be more than 10%
    - The stacker must be free from load.
    - The road surfacing must be solid and have a good grip.
- ❖ Travel routes must offer sufficient load-bearing capacity for the loaded truck.
- ❖ It is not permitted to use the stacker in areas where there is an explosive atmosphere!
- ❖ The stacker is not suitable for continuous use in cool-houses!

|                               |            |           |            |                                                                                     |
|-------------------------------|------------|-----------|------------|-------------------------------------------------------------------------------------|
| Ambient conditions            |            |           |            |  |
| Temperature                   | From<br>To | 14<br>113 | ° F<br>° F |                                                                                     |
| Degree of humidity            |            | ≤70       | %          |                                                                                     |
| Permitted floor<br>incline    |            |           |            |                                                                                     |
| • Loaded                      |            | Max. 0.5  | %          |                                                                                     |
| • Unloaded <sup>1</sup>       |            | Max. 2.0  | %          |                                                                                     |
| <b>Dimensions and weights</b> |            |           |            |                                                                                     |
| Mass (dead weight)            | m          | 1058/1654 | lbs        |                                                                                     |

1) When travelling between different buildings, etc.



### WARNING!

The user is responsible for determining the actual load bearing capacity of a high-lift stacking truck. This can depend on the user, the condition of both the floor and the high-lift stacking truck and the regularity of the maintenance intervals.

## Operation

---

### Raising the load



#### CAUTION!

- Before lifting the load to be transported, ensure that the load does not exceed the lifting capacity of the truck.
- The nominal lifting capacity and lifting heights can be viewed in the load chart on side of the cahnnel.
- Ensure that the load is lifted up in a compact and stable manner. Slipping or falling of the load must be avoided.
- The load must not project into the lifting frame. Load must be evenly distributed when lifting the forks.
- The load must not hang more than 2" over the end of the lifting forks.



### Moving the load



#### CAUTION!

- Raise the load only slightly to transport
- For safety reasons (view) transport only in a forward direction
- Only when raising or setting down the load, movement of the stacker should be avoided.
- Make sure to raise or set down loads on level surfaces
- With no load, move the truck with lowered forks

### When stacker not in use

- Park the stacker on level surfaces and not in the way of any other objects
- Lower the forks completely

## Operation

---

### Driving on sloping surfaces



#### CAUTION!

- If a load to be transported on a slope, the load must be faced slope-upwards
- It is not permissible to drive on a slopes diagonally.
- The max. Slope increase which can be driven is stated in the product description.



#### CAUTION!

This manner of driving is prohibited!



## Operation

### **Parking Brake:**



**To activate the parking brake, press down on the brake pedal**



To release the parking brake, press down on the brake pedal



### MAINTENANCE

#### Maintenance

| Maintenance interval | Fig. | Assembly/ component           | Action                                                                                                                                                                            |
|----------------------|------|-------------------------------|-----------------------------------------------------------------------------------------------------------------------------------------------------------------------------------|
| Before use           |      | Complete fork lift truck      | Check status, clean if necessary                                                                                                                                                  |
|                      |      | Hydraulic system<br>• General | Check for leaks(oil under the truck)<br>→ Tighten if any of the plug is loose                                                                                                     |
| Daily                | 1.1  | Load chain                    | Check for mechanical damage<br>Check for play (slack chain), see also "Maintenance and care of load chains"                                                                       |
| Monthly              | 2.1  | Load wheels                   | Check for wear                                                                                                                                                                    |
|                      | 2.2  | Load carries                  | Check complete load carriage for cracks<br>Inform after-sales service                                                                                                             |
| 6-monthly            | 3.1  | Load chain                    | Check the chain and chain connection for mechanical damage<br>Check for play(slack chain)<br>If required, treat with chain spray, see also "Maintenance and care of load chains". |
|                      | 3.2  | Mast                          | Clean the inside of the mast profile and grease slightly                                                                                                                          |
|                      |      | Load carriage/ load forks     | Check lateral play of the mast( in case of a dual-reach mast) and the load forks(do not completely raise the load forks)                                                          |

Hydraulic Oil: Check hydraulic oil level every six months.

Do not use brake fluid or jack oil in the hydraulic system. If oil is needed, use an anti-wear hydraulic oil with a viscosity grade of 150 SUS at 100°F, (ISO 32 @ 40° C), or a non-synthetic transmission fluid.

## **Maintenance and repair**

---

### **Maintenance and care of the load chains**

In normal use the load chains should be re-lubricated every 250 operating hours; in the event of heavy soiling, moisture and very high prolonged loading, re-lubrication should be effected after 100 operating hours. If subject to corrosive media the chain should be cleaned and lubricated immediately.

### **Chain lubrication, chain conservation**

Flyer chains are correctly lubricated and are in a perfect state if:

The chain is free of exterior soiling.

When touching the chain, your finger is wetted with oil. This assures that the lubrication of the chain links is sufficient.

### **Type of lubricant**

A low-viscosity mineral – machine – or engine oil or synthetic oil should be used. The viscosity of the lubricating oil is to selected so that it remains low viscose at all ambient temperatures encountered.

Under normal temperature conditions, lubricating oils with a viscosity of SAE 20 to SAE 40 would be appropriate.

### **Lubricating methods**

The lubricant can be applied by means of brush, paint brush or also using compressed air spray devices. When using spray cans, please make sure the following basic requirement is fulfilled:

- After the thinner has vaporized, a viscosity conforming to the above-mentioned recommendation (type of lubricant) must be met.

### **Cleaning the chain**

If operation leads the chain to suffer so heavily from soiling that the penetration of the lubricating oil cannot be guaranteed, the chain must be cleaned.

This is only to be effected with paraffin derivatives such as diesel fuel, petroleum, cleaner's naphtha etc.

Do not clean with steam injectors, cold cleaners or even corrosive and acidic substances. They can directly lead to chain damage.

If the chains have to be cleaned with steam injectors, please contact our customer service.

## **Maintenance and repair**

---

### **◆ Chain inspections**

Chains used in lift trucks should be inspected at least once a year or every three months if exposed to severe contamination or high continuous loading stress.

**Inspection notes**-we recommend that attention be paid to the following points:

1. Noise generation
2. Surface rust
3. Linkage rust
4. Stiff links
5. Distorted pins
6. Loose link pins
7. Impermissible external wear
8. Damage
9. Broken link plates
10. Broken pins
11. Contamination
12. Stretching

Even with the optimum amount of lubrication, it is impossible to prevent a chain from stretching.

**Wear extends only to that part of the chain which is led over the chain sprocket/guide sprocket. Thus, when checking for wear, only this area need be inspected.**

According to the regulations currently in force, a chain is deemed to be worn if it has stretched by 3%.

If safety issues are particularly critical or a potential hazard is dependent on a single chain, we consider it necessary to replace it if it is stretched by even 2%.

### **Measuring procedure**

To measure elongation through wear, that part of the chain which runs over the chain sprocket/guide sprocket must be positioned in the stretched area. With the aid of a measuring rod, measure a section approximately 1 meter in length.

The number of divisions in the measured area, multiplied by the chain divisions, gives the nominal measurement.

The length extending beyond this measurement represents the wear, which is limited to a maximum of 3% over the nominal length.

An elongation through wear of 3% is reached if 33 links of the chain in use measure the same length as 34 links of a new chain.

### **◆ Chain replacement**

If two chains are used as a pair on the affected machine, both should always be changed at the same time.

The installation and removal of chains should be carried out with all the care appropriate to any item of safety equipment.

Chains may only be repaired by authorized specialist personnel.

We do not recommend the lengthening of safety-type lifting chains, since the inserted chain link will not have been pre-stretched.

Our product liability will be invalidated if a repaired chain is assembled from sections bearing different silver label numbers.

## **Maintenance and repair**

---

### **◆ Temporary lay-up**

**For operating reasons, if stacker is put away without use for more than two months, the following instructions are to be carried out:**

- \* Clean the stacker thoroughly.
- \* It may be necessary to support the lifting gear in a suitable manner, so as to relieve any stress on the load chains.
- \* Check the hydraulic fluid level, replenish if necessary.
- \* Grease the vehicle thoroughly.
- \* Coat all bright and moving parts with a thin film of oil and grease respectively.
- \* Store the vehicle in a dry, frost-proof, dust-free place.
- \* Do not use plastic sheeting to cover the vehicle otherwise condensation could form under it.

### **Return to service after a lay-up**

- \* Thoroughly clean and grease the stacker.
- \* Remove the film of protective grease.
- \* Check the hydraulic fluid level and hydraulic fluid for condensation, if necessary carry out a fluid change.
- \* Inspect hydraulic hose lines for brittleness.
- \* Test the functions of the stacker, particularly the safety equipment.

### **Final withdrawal from service**

If a faulty vehicle can no longer be repaired to a condition in which it can be used as specified and in accordance with existing safety regulations, it must be finally withdrawn from service.

Having been dismantled into individual components (steel, plastics, electronics, consumables, etc.) it must be disposed of in accordance with the applicable environmental regulations.



# VHPS-2000-AA (2014)

## Main Assembly

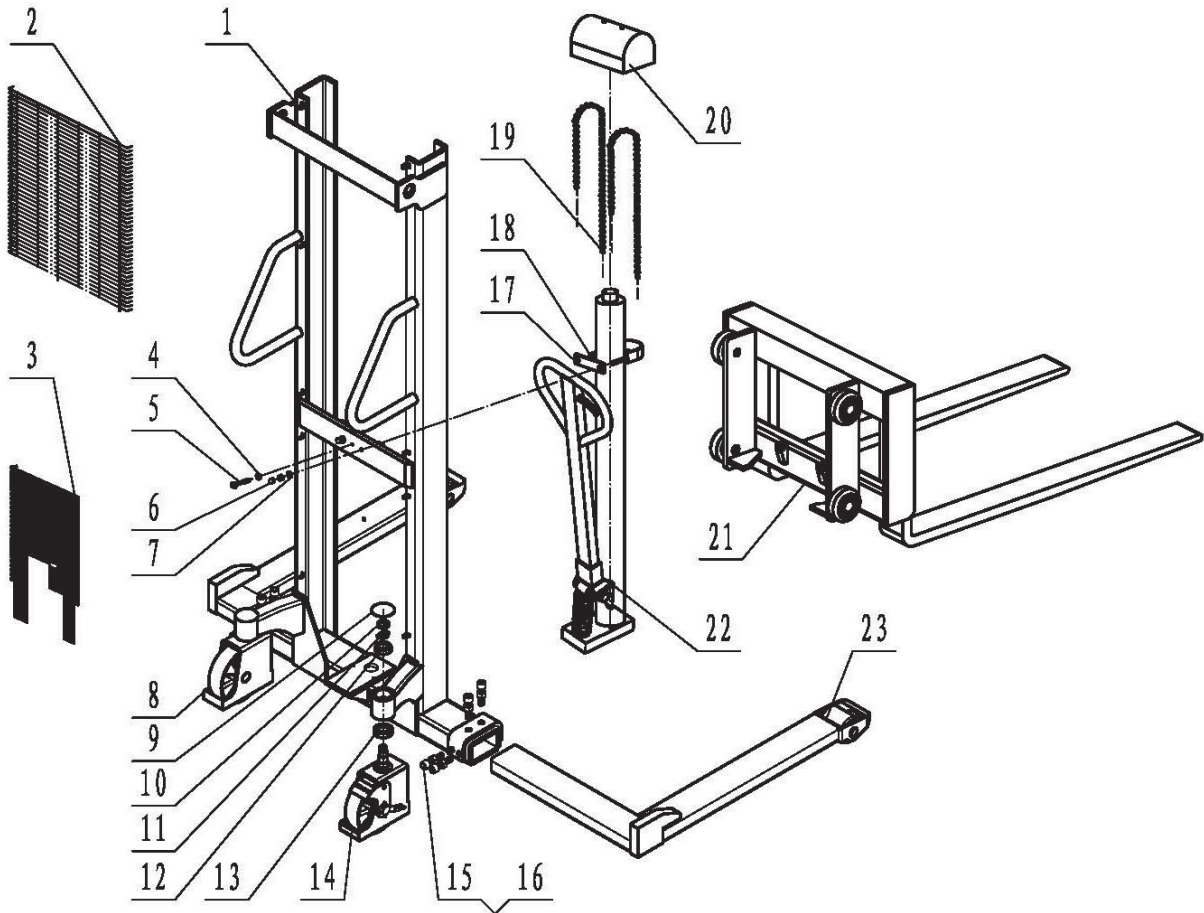

| VHPS-2000-AA (2014) Main Assembly |                       |      |                   |                                  |      |
|-----------------------------------|-----------------------|------|-------------------|----------------------------------|------|
| Part No.                          | Description           | Q'ty | Part No.          | Description                      | Q'ty |
| VHPS-2000-AA14-1                  | Frame                 | 1    | VHPS-2000-AA14-13 | Bearing 30205                    | 2    |
| VHPS-2000-AA14-2                  | Upper Wire Mesh       | 1    | VHPS-2000-AA14-14 | Swivel Wheel Assembly with Brake | 1    |
| VHPS-2000-AA14-3                  | Lower Wire Mesh       | 1    | VHPS-2000-AA14-15 | Bolt M16 x 60                    | 8    |
| VHPS-2000-AA14-4                  | Nut M10               | 3    | VHPS-2000-AA14-16 | Nut M16                          | 8    |
| VHPS-2000-AA14-5                  | Bolt M10 x 40         | 1    | VHPS-2000-AA14-17 | U-Clamp Bracket                  | 1    |
| VHPS-2000-AA14-6                  | Cup Nut M10           | 2    | VHPS-2000-AA14-18 | U-Clamp Bolt                     | 1    |
| VHPS-2000-AA14-7                  | Spring Washer M10     | 2    | VHPS-2000-AA14-19 | Chain LH1223                     | 2    |
| VHPS-2000-AA14-8                  | Swivel Wheel Assembly | 1    | VHPS-2000-AA14-20 | Chain Cover                      | 1    |
| VHPS-2000-AA14-9                  | Snap Ring             | 2    | VHPS-2000-AA14-21 | Fork Carriage Assembly           | 1    |
| VHPS-2000-AA14-10                 | Nut M20 x 1.5         | 2    | VHPS-2000-AA14-22 | Pump Assembly                    | 1    |
| VHPS-2000-AA14-11                 | Nut M20 x 1.5         | 2    | VHPS-2000-AA14-23 | Leg Assembly                     | 1    |
| VHPS-2000-AA14-12                 | Bearing 6204          | 2    |                   |                                  |      |

## Fork Assembly

| VHPS-2000-AA (2014) Fork Assembly |                |      |
|-----------------------------------|----------------|------|
| Part No.                          | Description    | Q'ty |
| VHPS-2000-AA14-F1                 | Carriage       | 1    |
| VHPS-2000-AA14-F2                 | Nut M6         | 4    |
| VHPS-2000-AA14-F3                 | Bolt M6 x 30   | 4    |
| VHPS-2000-AA14-F4                 | Bearing 30307V | 4    |
| VHPS-2000-AA14-F5                 | Snap Ring 35   | 6    |
| VHPS-2000-AA14-F6                 | Roller Plug    | 4    |
| VHPS-2000-AA14-F7                 | Fork           | 2    |
| VHPS-2000-AA14-F8                 | Fork Rod       | 1    |

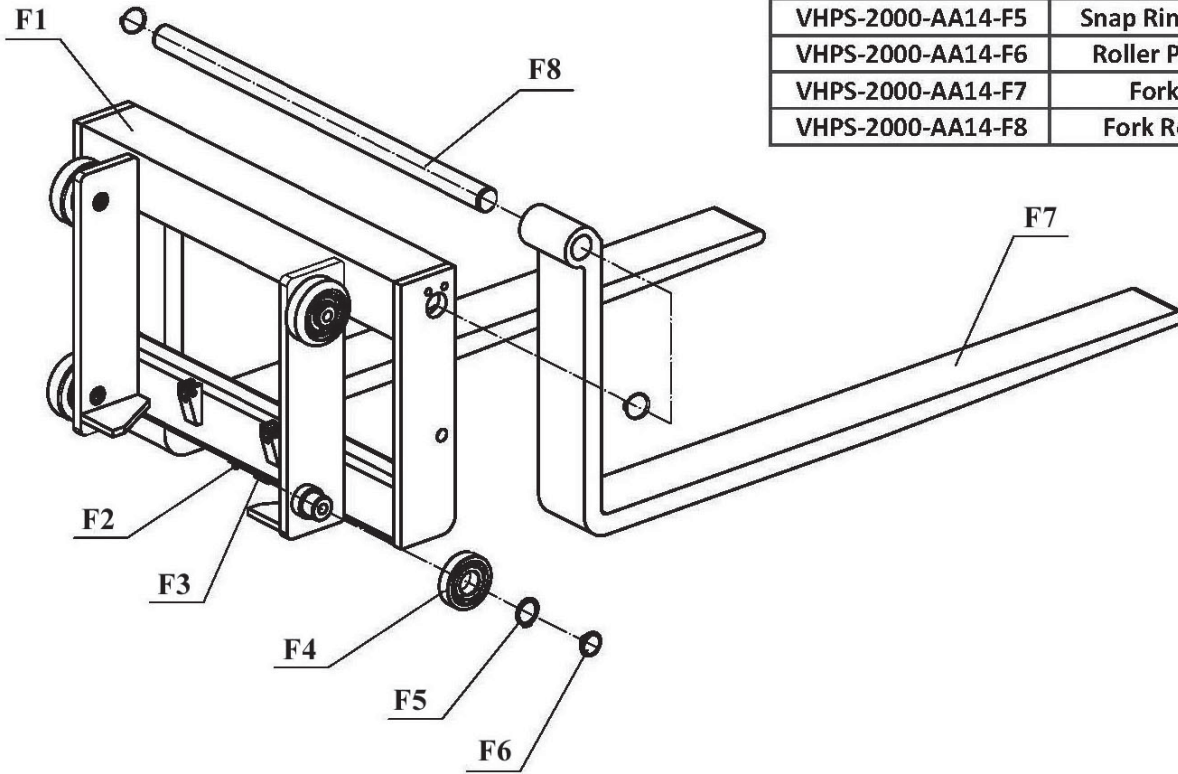

## Leg Assembly

| VHPS-2000-AA (2014) Leg Assembly |                             |      |
|----------------------------------|-----------------------------|------|
| Part No.                         | Description                 | Q'ty |
| VHPS-2000-AA14-L1                | Leg                         | 1    |
| VHPS-2000-AA14-L2                | Snap Ring 20                | 1    |
| VHPS-2000-AA14-L3                | Bearing 6204                | 2    |
| VHPS-2000-AA14-L4                | Nylon Load Roller 4 x 2.91" | 1    |
| VHPS-2000-AA14-L5                | Roll Pin                    | 1    |

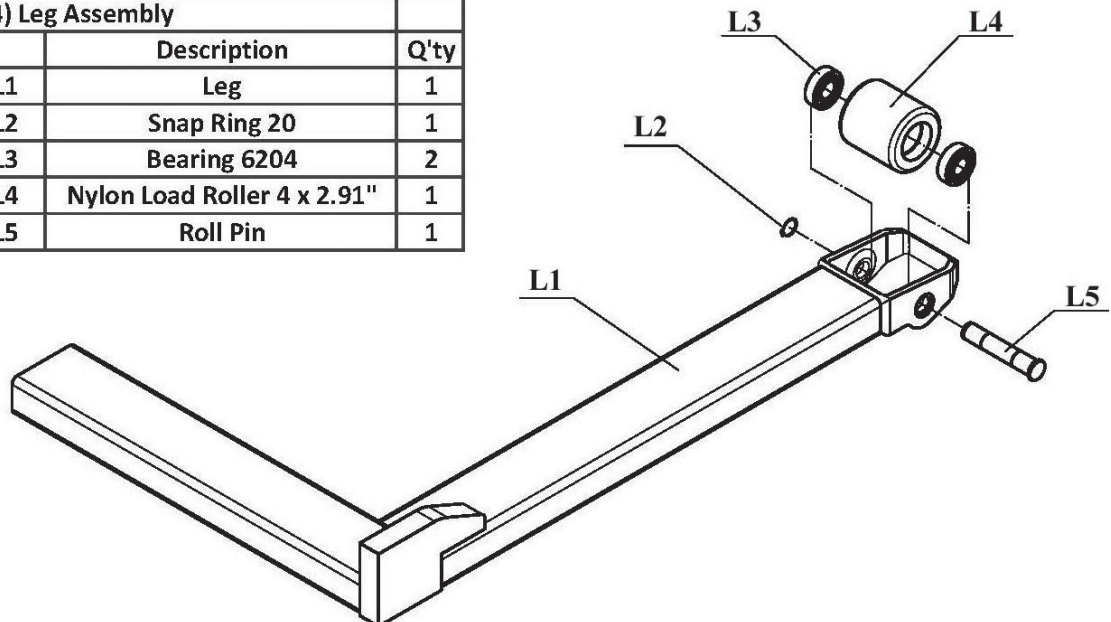

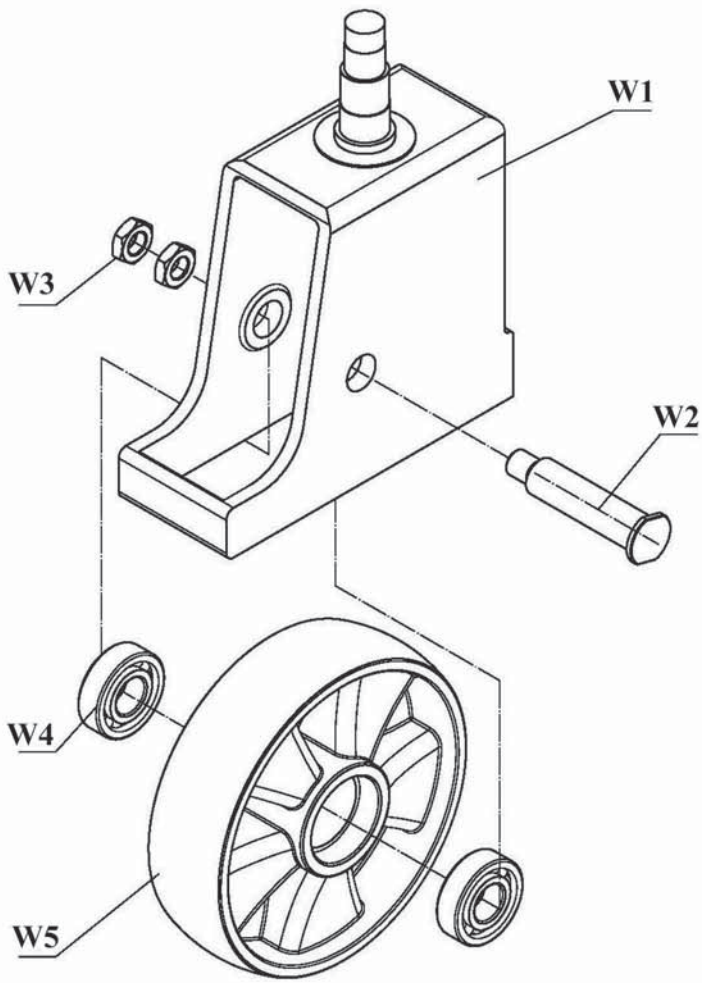

## Swivel Wheel Assembly

| VHPS-2000-AA (2014) Swivel Wheel Assembly |                         |      |
|-------------------------------------------|-------------------------|------|
| Part No.                                  | Description             | Q'ty |
| VHPS-2000-AA14-W1                         | Swivel Wheel Caster Rig | 1    |
| VHPS-2000-AA14-W2                         | Roll Pin                | 1    |
| VHPS-2000-AA14-W3                         | Nut M14                 | 2    |
| VHPS-2000-AA14-W4                         | Bearing 6204            | 2    |
| VHPS-2000-AA14-W5                         | Nylon 7 x 2" Wheel      | 1    |

## Swivel Wheel Assembly With Brake

| VHPS-2000-AA (2014) Swivel Wheel Assembly With Brake |                         |      |
|------------------------------------------------------|-------------------------|------|
| Part No.                                             | Description             | Q'ty |
| VHPS-2000-AA14-WB1                                   | Swivel Wheel Caster Rig | 1    |
| VHPS-2000-AA14-WB2                                   | Brake                   | 1    |
| VHPS-2000-AA14-WB3                                   | Pin                     | 1    |
| VHPS-2000-AA14-WB4                                   | Brake Lever             | 1    |
| VHPS-2000-AA14-WB5                                   | Roll Pin                | 1    |
| VHPS-2000-AA14-WB6                                   | Nut M14                 | 2    |
| VHPS-2000-AA14-WB7                                   | Bearing 6204            | 2    |
| VHPS-2000-AA14-WB8                                   | Nylon 7 x 2" Wheel      | 1    |

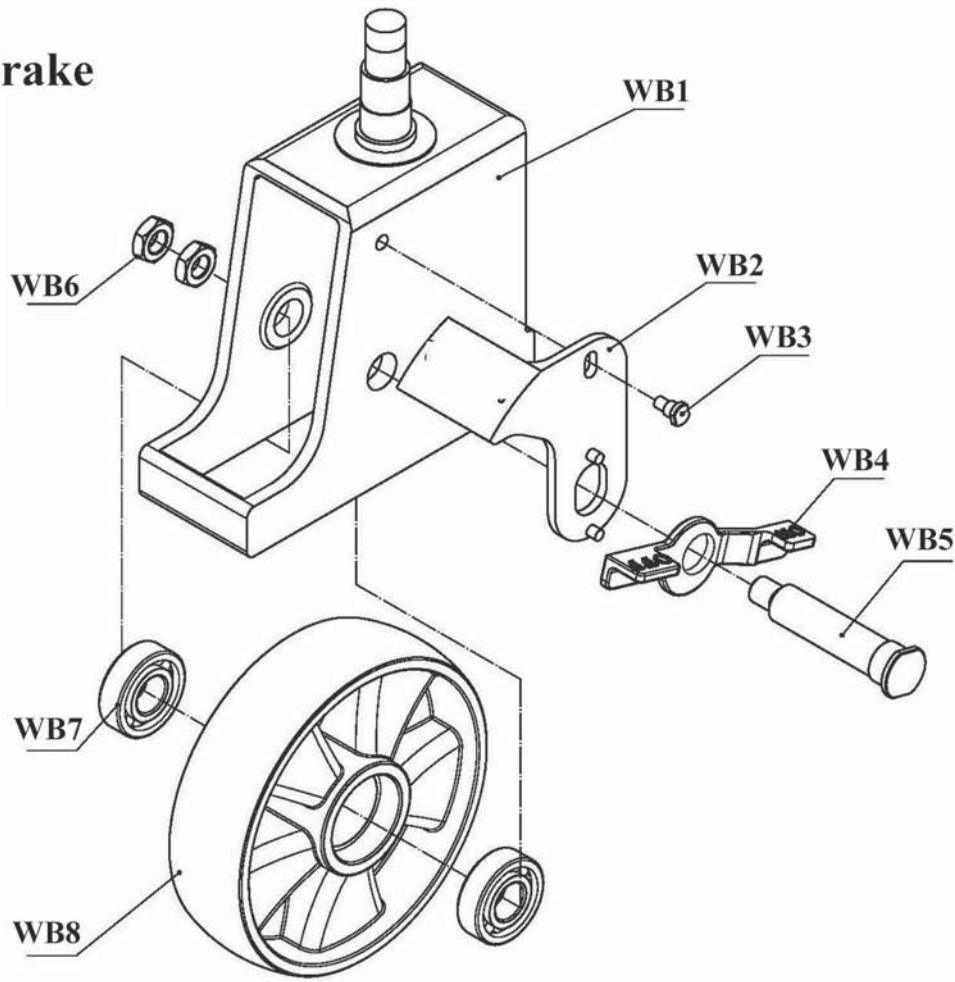

## Cylinder & Manifold Assembly

| VHPS-2000-AA (2014) Cylinder & Manifold Assembly |                   |      |                     |                    |      |
|--------------------------------------------------|-------------------|------|---------------------|--------------------|------|
| Part No.                                         | Description       | Q'ty | Part No.            | Description        | Q'ty |
| VHPS-2000-AA14-CM1                               | Tank              | 1    | VHPS-2000-AA14-CM16 | Screw              | 1    |
| VHPS-2000-AA14-CM2                               | Spring            | 1    | VHPS-2000-AA14-CM17 | Washer             | 1    |
| VHPS-2000-AA14-CM3                               | O-Ring 11.8 x 1.8 | 1    | VHPS-2000-AA14-CM18 | Nut                | 1    |
| VHPS-2000-AA14-CM4                               | Bushing           | 1    | VHPS-2000-AA14-CM19 | Spring             | 1    |
| VHPS-2000-AA14-CM5                               | Release Pin       | 1    | VHPS-2000-AA14-CM20 | Release Pin        | 1    |
| VHPS-2000-AA14-CM6                               | O-Ring 7.5 x 1.8  | 2    | VHPS-2000-AA14-CM21 | Housing            | 1    |
| VHPS-2000-AA14-CM7                               | Release Bracket   | 1    | VHPS-2000-AA14-CM22 | O-Ring 9 x 1.8     | 1    |
| VHPS-2000-AA14-CM8                               | Roll Pin          | 1    | VHPS-2000-AA14-CM23 | Ball 5/16          | 1    |
| VHPS-2000-AA14-CM9                               | Washer 6          | 1    | VHPS-2000-AA14-CM24 | Roll Pin           | 1    |
| VHPS-2000-AA14-CM10                              | Nut M6            | 1    | VHPS-2000-AA14-CM25 | Plug               | 1    |
| VHPS-2000-AA14-CM11                              | Screw M6 x 20     | 1    | VHPS-2000-AA14-CM26 | O-Ring 14 x 1.8    | 2    |
| VHPS-2000-AA14-CM12                              | Snap Ring         | 1    | VHPS-2000-AA14-CM27 | Plug               | 1    |
| VHPS-2000-AA14-CM13                              | Ball 1/4          | 1    | VHPS-2000-AA14-CM28 | Flow control Valve | 1    |
| VHPS-2000-AA14-CM14                              | Release Pin       | 1    | VHPS-2000-AA14-CM29 | Plug               | 1    |
| VHPS-2000-AA14-CM15                              | Spring            | 1    |                     |                    |      |

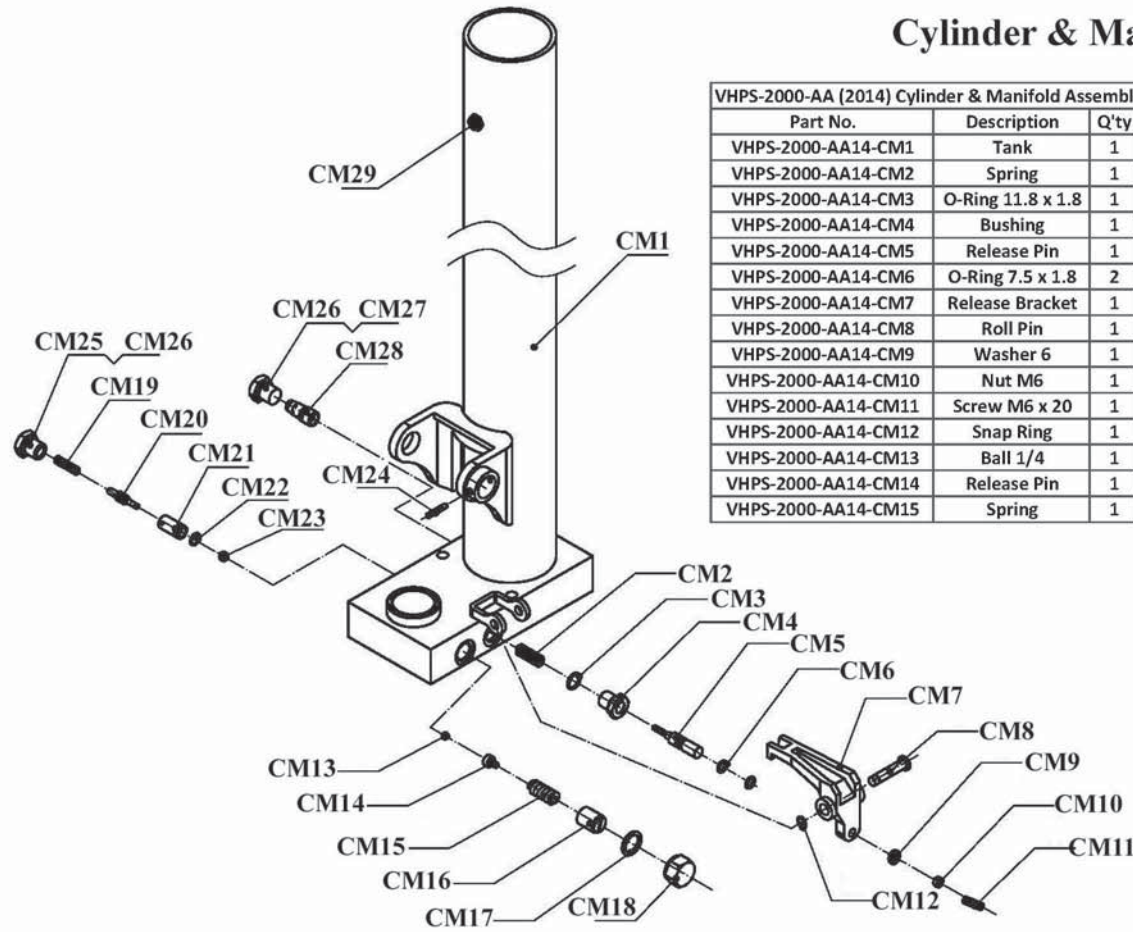

## Handle Assembly

| VHPS-2000-AA (2014) Handle Assembly |             |      |                    |                |      |
|-------------------------------------|-------------|------|--------------------|----------------|------|
| Part No.                            | Description | Q'ty | Part No.           | Description    | Q'ty |
| VHPS-2000-AA14-H1                   | Handle      | 1    | VHPS-2000-AA14-H12 | Roll Pin       | 1    |
| VHPS-2000-AA14-H2                   | Cover       | 1    | VHPS-2000-AA14-H13 | Nut            | 4    |
| VHPS-2000-AA14-H3                   | Screw       | 4    | VHPS-2000-AA14-H14 | Shaft          | 1    |
| VHPS-2000-AA14-H4                   | Ball        | 1    | VHPS-2000-AA14-H15 | Nut            | 1    |
| VHPS-2000-AA14-H5                   | Spring      | 1    | VHPS-2000-AA14-H16 | Screw          | 1    |
| VHPS-2000-AA14-H6                   | Screw       | 4    | VHPS-2000-AA14-H17 | Release Handle | 1    |
| VHPS-2000-AA14-H7                   | Handle Tube | 1    | VHPS-2000-AA14-H18 | Steel Wire     | 1    |
| VHPS-2000-AA14-H8                   | Screw       | 1    | VHPS-2000-AA14-H19 | Chain          | 1    |
| VHPS-2000-AA14-H9                   | Bracket     | 1    | VHPS-2000-AA14-H20 | Pull Rod       | 1    |
| VHPS-2000-AA14-H10                  | Wheel       | 1    | VHPS-2000-AA14-H21 | Nut            | 1    |
| VHPS-2000-AA14-H11                  | Roll Pin    | 1    |                    |                |      |

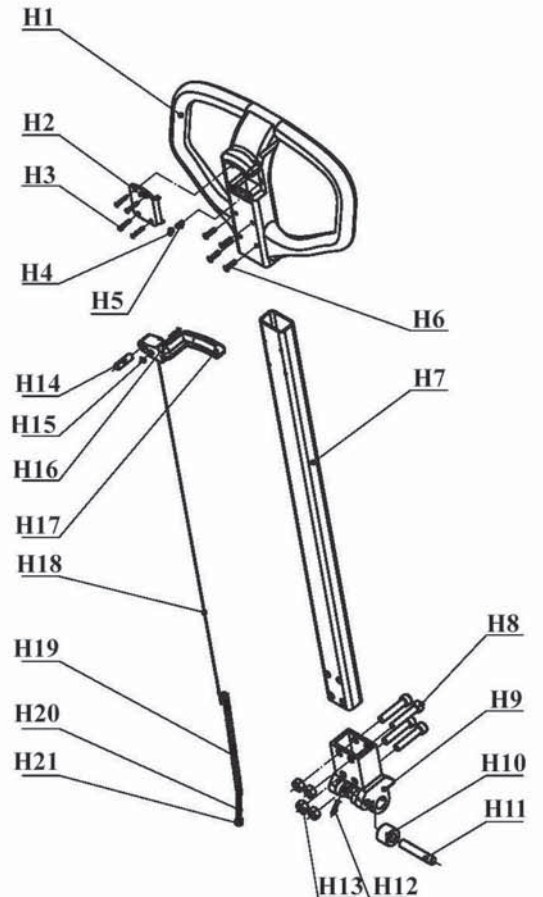

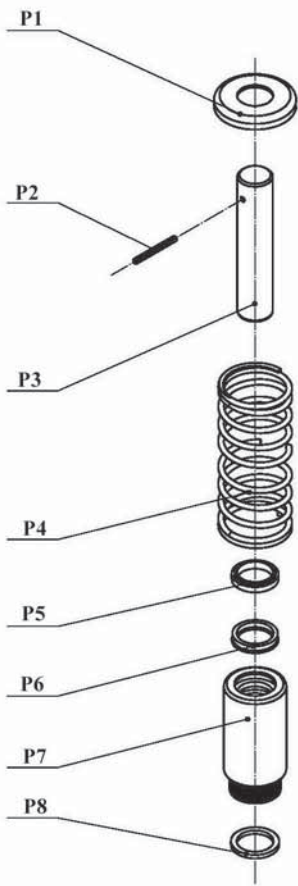

## Pump Assembly

| VHPS-2000-AA (2014) Pump Assembly |             |      |
|-----------------------------------|-------------|------|
| Part No.                          | Description | Q'ty |
| VHPS-2000-AA14-P1                 | Washer      | 1    |
| VHPS-2000-AA14-P2                 | Roll Pin    | 1    |
| VHPS-2000-AA14-P3                 | Pump Piston | 1    |
| VHPS-2000-AA14-P4                 | Spring      | 1    |
| VHPS-2000-AA14-P5                 | Wiper Seal  | 1    |
| VHPS-2000-AA14-P6                 | Seal        | 1    |
| VHPS-2000-AA14-P7                 | Housing     | 1    |
| VHPS-2000-AA14-P8                 | Wahser      | 1    |

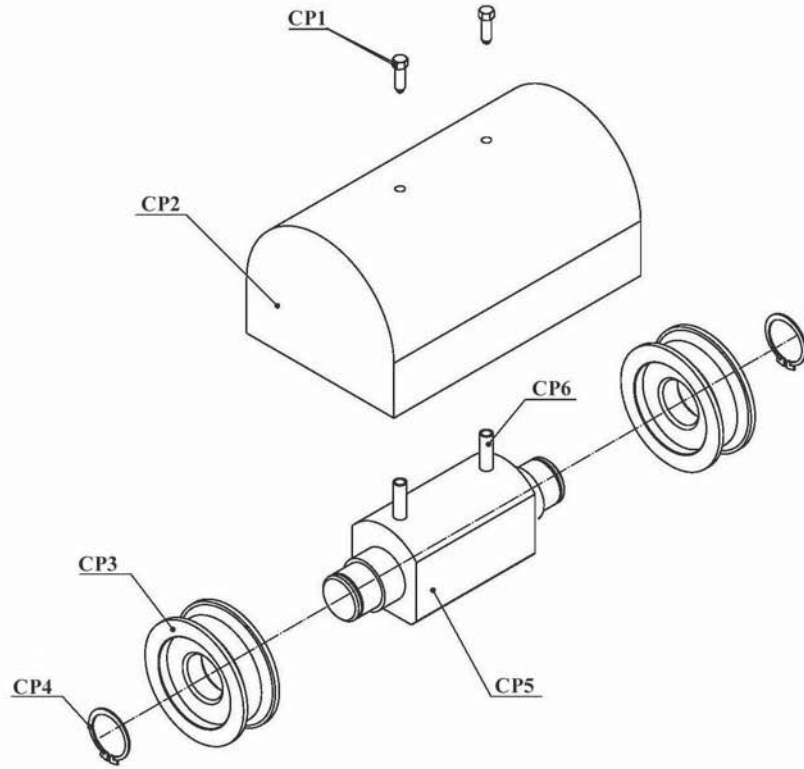

## Chain Pulley Guard Assembly

| VHPS-2000-AA (2014) Chain Pulley Guard Assembly |                     |      |
|-------------------------------------------------|---------------------|------|
| Part No.                                        | Description         | Q'ty |
| VHPS-2000-AA14-CP1                              | Chain Cover Screw   | 2    |
| VHPS-2000-AA14-CP2                              | Chain Cover         | 1    |
| VHPS-2000-AA14-CP3                              | Chain Wheel 780306V | 2    |
| VHPS-2000-AA14-CP4                              | Snap Ring 30        | 2    |
| VHPS-2000-AA14-CP5                              | Chain Wheel Seat    | 1    |
| VHPS-2000-AA14-CP6                              | Spacer              | 2    |

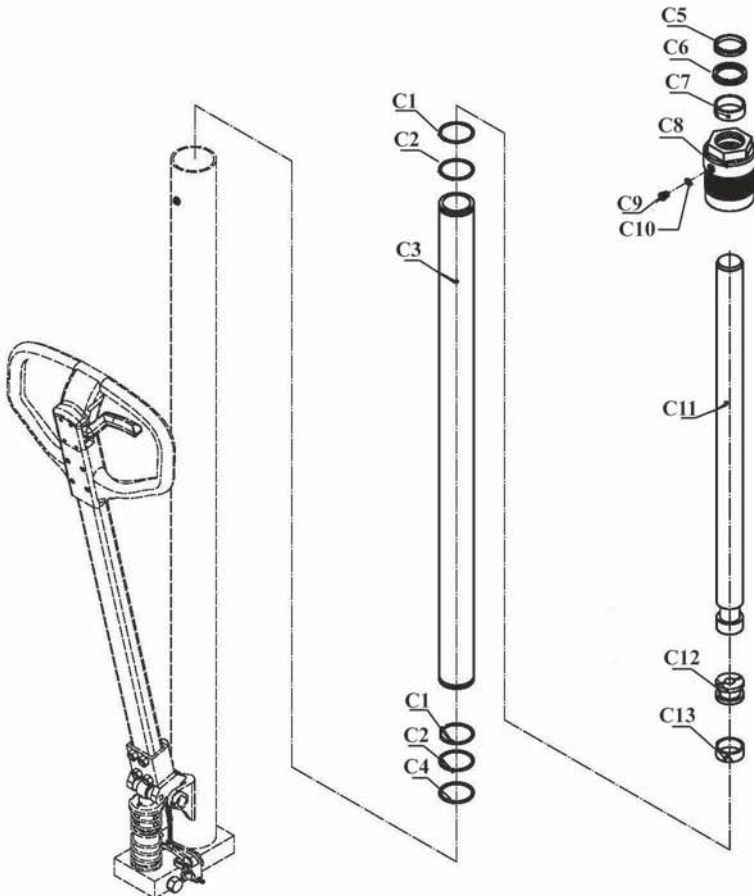

## Cylinder Assembly

| VHPS-2000-AA (2014) Cylinder Assembly |                     |      |
|---------------------------------------|---------------------|------|
| Part No.                              | Description         | Q'ty |
| VHPS-2000-AA14-C1                     | O-Ring 45 x 2.65    | 1    |
| VHPS-2000-AA14-C2                     | Ring 45             | 1    |
| VHPS-2000-AA14-C3                     | Lifting Rod Housing | 1    |
| VHPS-2000-AA14-C4                     | Ring                | 1    |
| VHPS-2000-AA14-C5                     | Wiper Seal          | 1    |
| VHPS-2000-AA14-C6                     | U-Cups Seal         | 1    |
| VHPS-2000-AA14-C7                     | PTFE Ring           | 1    |
| VHPS-2000-AA14-C8                     | Guide Bushing       | 1    |
| VHPS-2000-AA14-C9                     | Plug                | 1    |
| VHPS-2000-AA14-C10                    | O-Ring 6.3 x 1.8    | 1    |
| VHPS-2000-AA14-C11                    | Lifting Rod         | 1    |
| VHPS-2000-AA14-C12                    | Piston              | 2    |
| VHPS-2000-AA14-C13                    | PTFE Ring           | 1    |

## LIMITED WARRANTY

Vestil Manufacturing Corporation (Vestil) warrants each model SE/HP, S-CB, SL-series, S-series or VHPS-2000-AA Stacker to be free of defects in material and workmanship during the warranty period. Our warranty obligation is to provide a replacement for a defective original part (a part used to make the product as shipped to the warrantee) after we receive a proper request for warranty service. "Proper request" means that we must receive: 1) a photocopy of your Customer Invoice that displays the shipping date; AND 2) a written request for warranty service that includes your name and phone number. Send requests by any of the following methods:

|                                                                                             |                                                  |                  |
|---------------------------------------------------------------------------------------------|--------------------------------------------------|------------------|
| <u>Mail</u>                                                                                 | <u>Fax</u>                                       | <u>Email</u>     |
| Vestil Manufacturing Corporation<br>2999 North Wayne Street, PO Box 507<br>Angola, IN 46703 | (260) 665-1339<br><u>Phone</u><br>(260) 665-7586 | sales@vestil.com |

In the written request, list the parts you believe are defective and include the address where replacements should be delivered. After Vestil receives your request, an authorized representative will contact you to determine whether your claim is covered by the warranty (also see "If a defective part is covered..." below). Before providing warranty service, Vestil may require you to send the entire product or the defective part or parts to its facility in Angola, Indiana.

### Who may request service?

Only the warrantee may request service. *You are a warrantee if* you purchased the product from Vestil or from an authorized distributor AND Vestil has been fully paid.

### What is covered under the warranty?

The warranty covers the following *original* drive and lift components: drive motors and lift motors, hydraulic pumps, electronic controllers, switches and cylinders. It also covers *original* parts that wear under normal usage conditions ("wearing parts"): bearings, hoses, wheels, seals, brushes, batteries, and the battery charger. The warranty period for drive and lift components is 1 year. For wearing parts, the warranty period is 90 days. Both warranty periods begin on the date when Vestil ships the product to the warrantee. If you purchased the product from an authorized distributor, the periods begin when the distributor ships the product, which extends the warranty by up to an additional 30 days.

### If a defective part is covered by the warranty, what will Vestil do to correct the problem?

Vestil will provide an appropriate replacement for any *covered* part. An authorized representative of Vestil will contact you to discuss your claim.

### What is not covered by the warranty?

1. Labor costs or Freight;
2. Any of the following automatically void the warranty:
  - Product misuse;
  - Negligent operation or repair;
  - Corrosion or use in corrosive conditions;
  - Inadequate or improper maintenance;
  - Failure to exercise good judgment;
  - Damage sustained during shipping;
  - Accidents involving the product;
  - Unauthorized modifications: Do NOT modify the product IN ANY WAY without first receiving written authorization from Vestil. Modifications may render the pallet truck or stacker unsafe to use or might cause excessive and/or abnormal wear.

### Do any other warranties apply to the product?

Vestil Manufacturing Corp. makes no other express warranties. Any warranty implied-by-law is limited in duration to the warranty period.

